

Normaali tankki

Pumpun paine

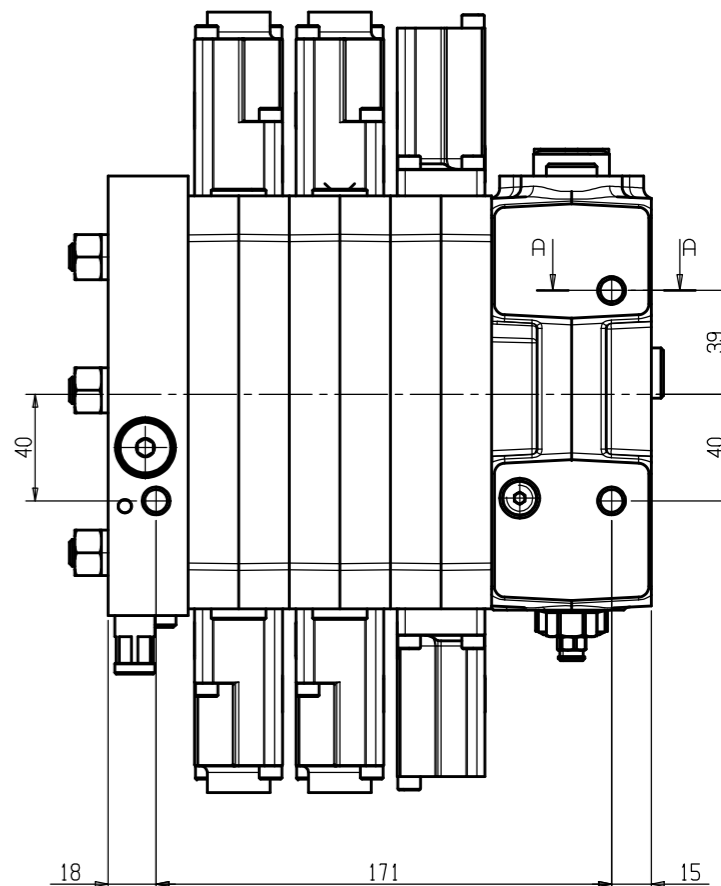
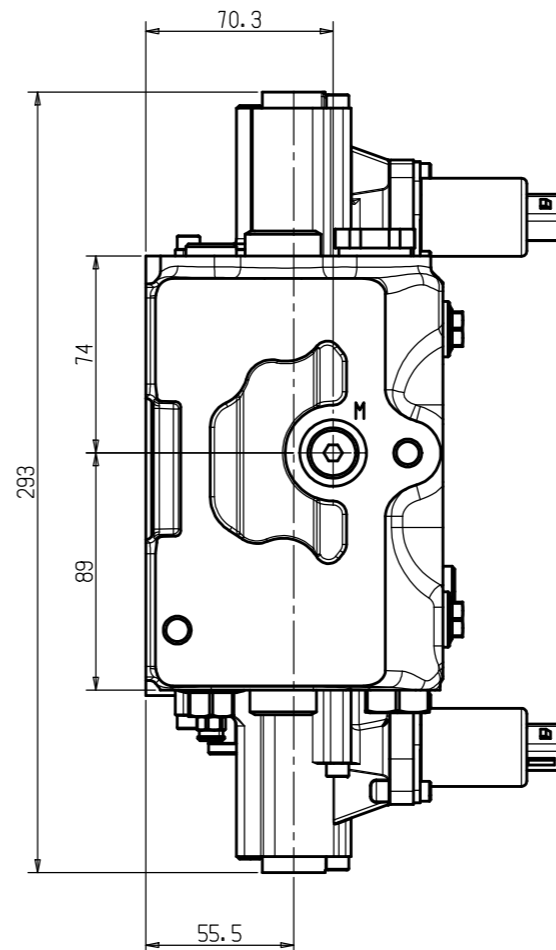
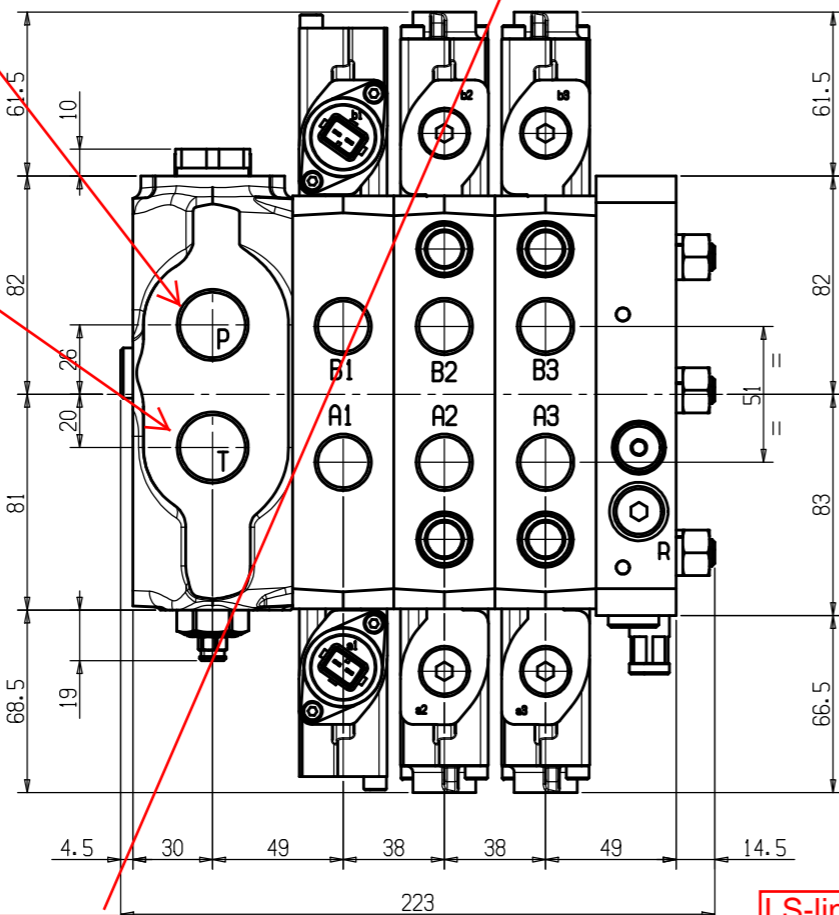
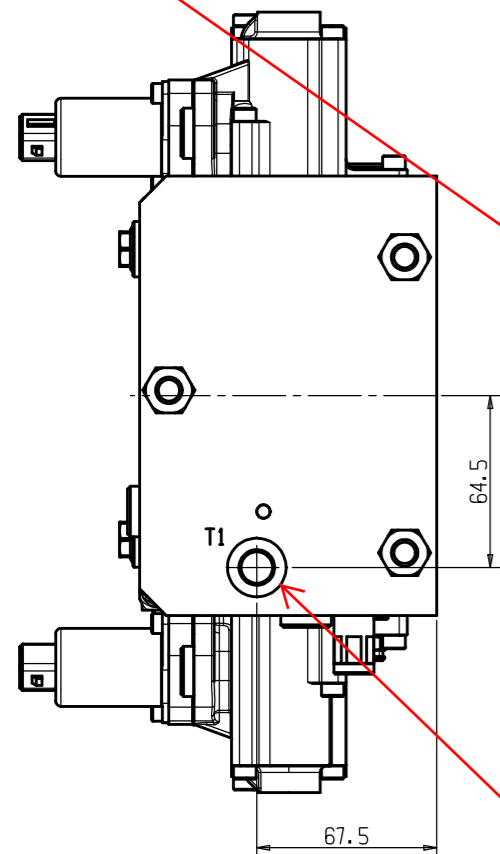

Vuoto, joko T1 tai T2 paineettomaan tankkiin.

LS-linja pumpulta, jos LS-järjestelmä ja LS-pääty

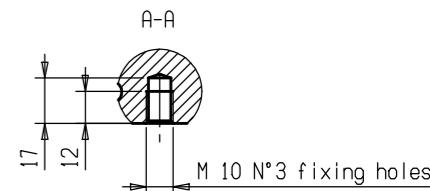
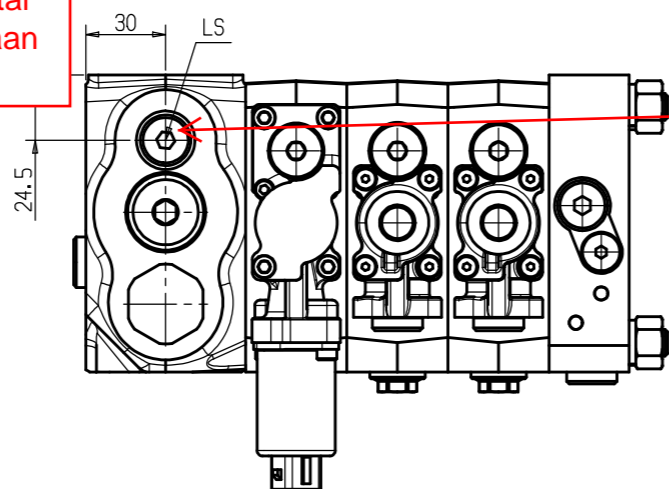

PAINTING COLOR: BLACK RAL9005

HC-EX38/3  
ML 701 200 KV G04  
W002C 9090 H407 RC2 G04  
W001C 8080 H005C RC1 G04 03PA 180 05PB  
W001C 8080 H005C RC1 G04 03PA 180 03PB 180  
KZ20EH \*  
P006/3 N10  
Code: 60150282SD

Description: HC-EX38/3 CA



Group:	EX38	Scale:	
Approv.:	Adm	Date:	29/04/2015
Designer:	SD	Date:	29/04/2015
Schema Code:	60150282SD	CODE:	I07601
Mod.:	0		